

断面図

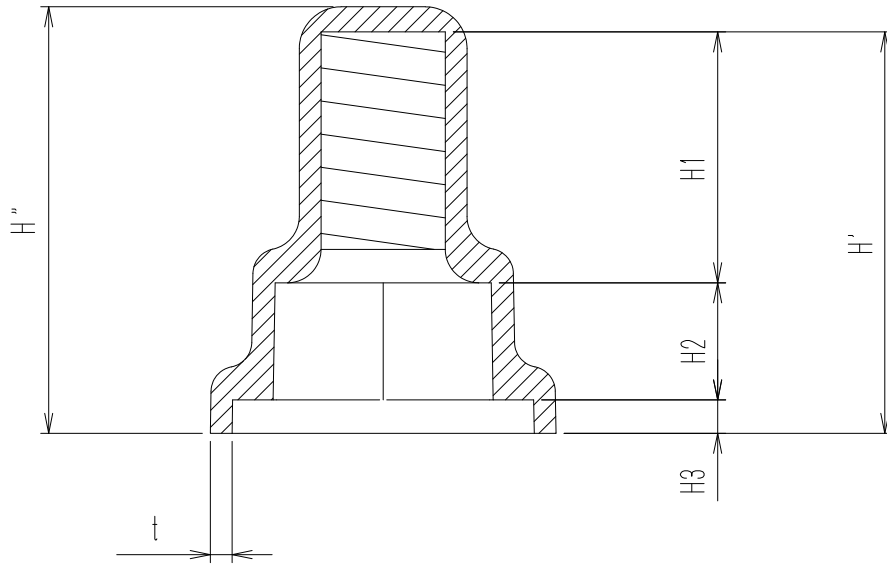

上面図

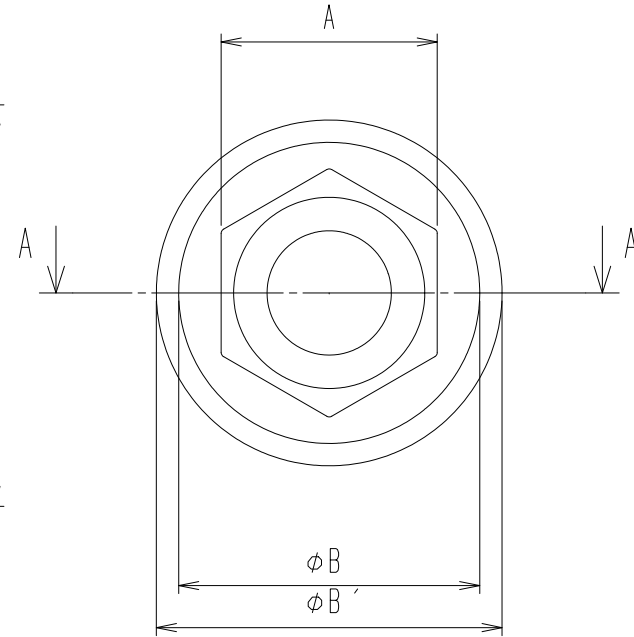

サイズ	ブラック[Black]	ホワイト[White]	グレー[Gray]	イエロー[Yellow]	アイボリー[Ivory]	ブルー[Blue]	レッド[Red]
	品番	品番	品番	品番	品番	品番	品番
M6	EA30210-0006	EB30210-0006	EC30210-0006	EE30210-0006	ED30210-0006	EF30210-0006	EG30210-0006
M8	EA30210-0008	EB30210-0008	EC30210-0008	EE30210-0008	ED30210-0008	EF30210-0008	EG30210-0008
M10	EA30210-0010	EB30210-0010	EC30210-0010	EE30210-0010	ED30210-0010	EF30210-0010	EG30210-0010
M12	EA30210-0012	EB30210-0012	EC30210-0012	EE30210-0012	ED30210-0012	EF30210-0012	EG30210-0012
M16	EA30210-0016	EB30210-0016	EC30210-0016	EE30210-0016	ED30210-0016	EF30210-0016	EG30210-0016
M20	EA30210-0020	EB30210-0020	EC30210-0020	EE30210-0020	ED30210-0020	EF30210-0020	EG30210-0020
M22	EA30210-0022	EB30210-0022	EC30210-0022	EE30210-0022	ED30210-0022	EF30210-0022	EG30210-0022
M24	EA30210-0024	EB30210-0024	EC30210-0024	EE30210-0024	ED30210-0024	EF30210-0024	EG30210-0024
W3/8	EA30210-0308	EB30210-0308	EC30210-0308	EE30210-0308	ED30210-0308	EF30210-0308	EG30210-0308
W1/2	EA30210-0102	EB30210-0102	EC30210-0102	EE30210-0102	ED30210-0102	EF30210-0102	EG30210-0102

サイズ	寸法								
	A	ΦB	ΦB'	H1	H2	H3	H'	H''	t
M6	10	13.1	15.1	15	5	2	22	23.2	1
M8	13	18.1	20.7	15	7	2	24	25.5	1.3
M10	17	22.1	24.7	15	8	2	25	26.5	1.3
M12	19	26.1	29.1	20	10	3	33	35	1.5
M16	24	32.1	36.1	25	13	3	41	43	2
M20	30	40.1	44.1	30	16	4	50	52	2
M22	32	44.1	49.1	40	18	4	62	64.5	2.5
M24	36	48.2	53.2	50	19	5	74	76.5	2.5
W3/8	17	25.1	27.7	15	8	3	26	27.5	1.3
W1/2	21	32.1	35.1	20	10	3	33	35	1.5

品名 PRODUCT NAME		サイズ SIZE	
ELシングルナットワッシャー付キャップ		M6~M24	
材質 MATERIAL	色 COLOR		
エラストマー (TPE)	ブラック・ホワイト・グレー・アイボリー イエロー・ブルー・レッド・ブラウン		
品番 PARTS NO.	縮尺 SCALE	担当 IN CHARGE	製図 DRAWN
30210-	Non	M.Ishida	24.06.20